

Think GAIA
For Life and the Earth

SANYO

**-80°C Ultra-Low Temperature
V.I.P.™ Freezer**

MDF-C8V1



MDF-C8V1

VIP
Vacuum Insulation Panel series

Temperature
(Ambient temp. 30°C)

-80°C

Effective capacity

84 Liter / 3.0 cu.ft.

Patented V.I.P.™
(Vacuum Insulation Panel)

Personal size, space saving Ultra-Low Freezer with Improved energy consumption

- New V.I.P. PLUS™ technology maximises storage capacity
- Space-saving design enables effective use of laboratory space
- Filterless structure makes cleaning unnecessary
- Alarms secure valuable samples safety
- Low noise design
- Achieves energy savings of approx. 40%*

*SANYO comparison

MDF-C8V1

Features

More advanced insulation system: V.I.P. PLUS™

SANYO's more advanced insulation system V.I.P. PLUS™ enables reducing the thickness of insulation to approximately one half compared to conventional systems. Small freezers such as MDF-C8V1 takes full advantage of this feature.

Use of V.I.P. PLUS™ insulation material on the front, left, and right sides enables a smaller installation space with the highest-class storage capacity ratio.

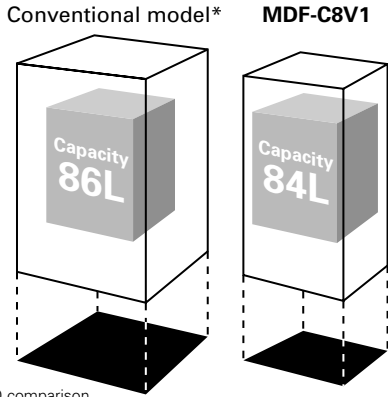

*SANYO comparison

Installation space **0.525m²** **0.377m²**

Newly developed single-compressor system

Use of a newly developed single-compressor system achieves an approximately 40% reduction in power consumption and enables low-noise operation.

	Rated power consumption
MDF-C8V1	340W/330W
Conventional model*	550W/600W

*SANYO comparison (115V, 60Hz/230V, 50Hz)

Specifications

Model	MDF-C8V1
Temperature range	-60 to -80°C (1°C increments)
Maximum cooling performance	-80°C (Ambient temp. 30°C)
Exterior dimensions (W x D x H)	550 x 685 x 945 mm (21.6" x 27.0" x 37.2")
Interior dimensions (W x D x H)	405 x 490 x 425 mm (15.9" x 19.3" x 16.7")
Effective capacity	84 Liter (3.0 cu.ft.)
Net weight	Approx. 67 kg (148 lbs.)
Storage capacity	2" box: 42pcs. (IR-207C x 6 racks)
Outer door/Inner door	Outer Lid: 1piece, Inner Lid: 1piece (PS + PE foam)
Insulation	New VIP + Rigid polyurethane foam (HC)
Cooling system	New mixed refrigerant cooling system
Compressor	Rotary type, Output: 400W
Refrigerant	HFC
Evaporator	Tube on sheet type
Alarm system	<ul style="list-style-type: none"> High/Low temp. alarm (±5°C to ±20°C) Power failure alarm Remote alarm contact: DC30V, 2A

*Cooling performance is indicated by the temperature reached at the center of the freezer (at ambient temperature of 30°C with no load). In order to use the freezer at a stable temperature for a long time, it is recommended that the temperature be set to at least 5°C higher than the indicated lowest temperature. In addition, depending on the usage conditions, it may not be possible to reach the indicated lowest temperature.

Caution:

SANYO guarantees the product under certain warranty conditions.

SANYO in no way shall be responsible for any loss of content or damage to content.

• Appearance and specifications are subject to change without notice.

New cooling circuit enables filterless structure

A new cooling circuit makes the inconvenient customer maintenance procedure of filter cleaning unnecessary.

Performance Data

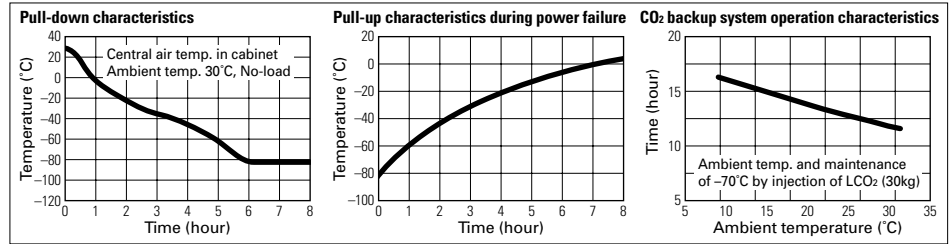

Dimensions

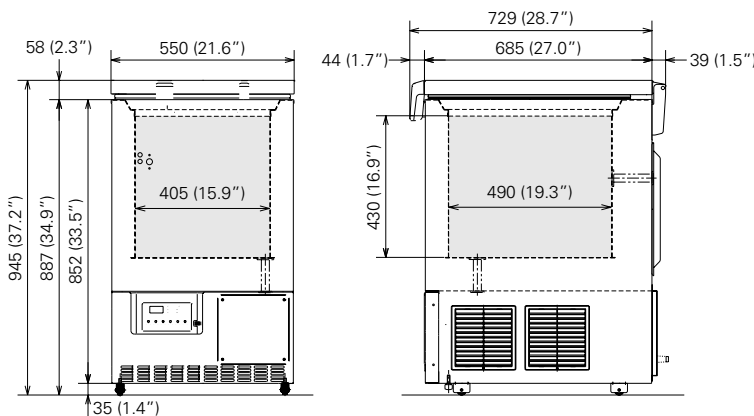

[Unit: mm (inch)]

Options

LCO₂ Back-up system



CVK-UB4
Back-up system mounting kit
MDF-UBK

Temperature recorders



Circular recorder
MTR-G85

Sensor cover
MTR-C8

Inventory rack
IR-207C



Strip chart recorder
MTR-85H

Recorder mounting kit
MDF-S3085
(for MTR-85H)

SANYO Electric Co., Ltd., Biomedical Division, Gunma is certified for:

Quality management system: ISO9001 / Medical devices quality management system: ISO13485 / Environmental management system: ISO14001

RoHS (European Restriction of Hazardous Substances directives) compliant

Distributed by:

SANYO

SANYO Electric Co., Ltd.
Biomedical Division
<http://www.sanyo.co.jp/cm/g/biomedical>

©2008 SANYO Printed in Japan 2008.12 MA
SHR135